

**LUCI**

- ▣ [Team](#)
- ▣ [MOS unit](#)
- ▣ [Consortium](#)
- ▣ [LMS Software](#)
- ▣ [Gallery](#)
- ▣ [Links](#)
- ▣ [Internal](#)

## LUCI A Near-Infrared Camera & Spectrograph for the LBT

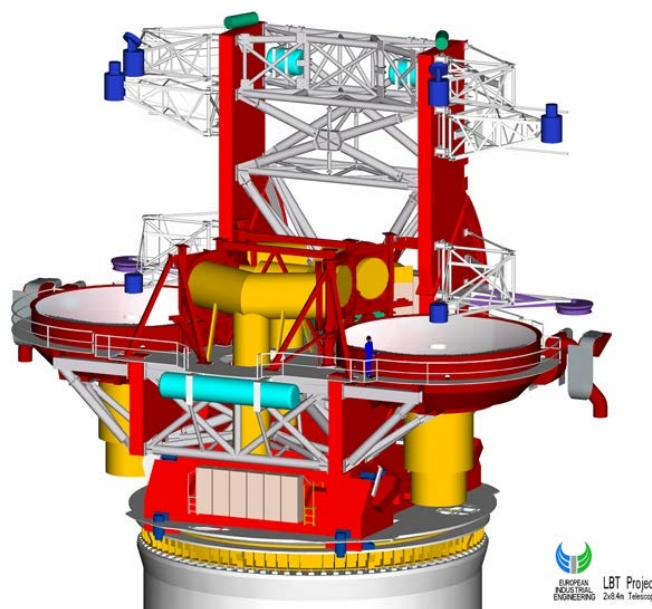

Fig.1: 3d-model of the LBT

The **LBT** (*Large Binocular Telescope*) is a collaboration between astronomical institutes in Germany, Italy, and the US. The telescope is located on Mount Graham, near Tucson, Arizona at an altitude of about 3200 m. The LBT is a binocular telescope consisting of two 8.4-meter mirrors on a common mount (Fig. 1). This telescope is equivalent in light-gathering power to a single 11.8 meter instrument. Because of its binocular arrangement, the telescope achieves a resolving power corresponding to a 22.8-meter telescope. A major innovative feature of the LBT is the integrated adaptive optics (which compensates the image perturbation caused by atmospheric turbulences). The essential component of an adaptive optics system is a deformable mirror which corrects the wavefront deformations in realtime. At the LBT, the secondary mirrors provide the deformable surfaces, therefore, in contrary to other telescopes, no additional components in the optical path are required. This configuration minimizes the instrumental background radiation and thus makes the LBT well suited for infrared observations.

The telescope mount was completed in Italy and shipped to Arizona in the summer of 2002. The two 8.4-meter primary mirrors have been molded and polished by the University of Arizona Mirror Lab. The first mirror arrived on the mountain in September 2003, the second one in September 2005. The first deformable secondary was delivered in 2010, the second one in 2012.

The LBT observing instruments split into single beam instruments receiving light from one primary mirror only, and instruments combining the beams of the two mirrors while conserving their phase relation (interferometers). Each of the two telescopes is equipped with three single beam instruments: a prime focus camera, an optical spectrograph (MODS), and a near-infrared instrument (LUCI, formerly LUCIFER). The beams of the two primary mirrors are combined in a near- to mid-infrared interferometer (LINC-NIRVANA) and in an optical to near-infrared interferometer (LBTI). The first prime-focus camera arrived at the telescope in 2005. First light for LUCI 1 was obtained in 2008, regular observing started at the end of 2009. MODS 1 came to the telescope in 2011. Shipping of both MODS 2 and LUCI 2 is planned in 2013.

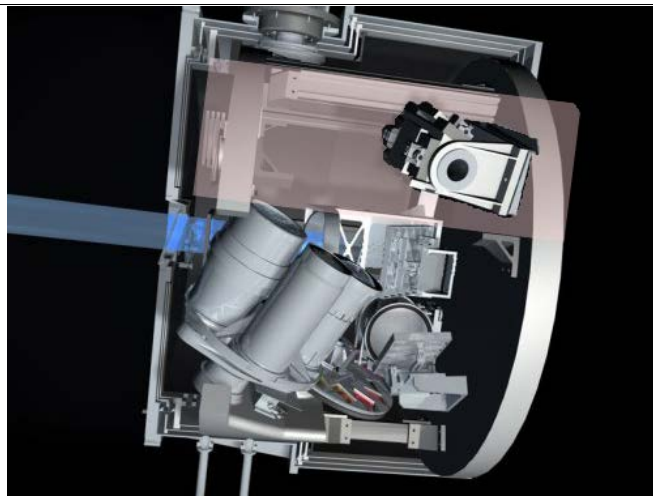

Fig.2: Cut through the LUCI cryostat. The pink area indicates the location of the MOS-unit.

LUCIFER (LBT Near Infrared Spectroscopic Utility with Camera and Integral Field Unit for Extragalactic Research) is the near-infrared instrument for the LBT. The name of the instrument was officially changed to **LUCI** in 2012. LUCI operates in the 0.9 - 2.5  $\mu\text{m}$  spectral range using a 2048 x 2048 element Hawaii II detector array from Rockwell and provides imaging and spectroscopic capabilities in seeing- and diffraction limited modes. In its focal plane area, long-slit and multi-slit masks can be installed for single- and multi-object spectroscopy. A fixed collimator produces an image of the entrance aperture in which either a mirror (for imaging) or a grating can be positioned. Three camera optics with numerical apertures of 1.8, 3.75 and 30 provide image scales of 0.25, 0.12, and 0.015 arcsec/detector element for wide field, seeing-limited and diffraction-limited observations. Like all infrared instruments, LUCI is operated at cryogenic temperatures, and is therefore enclosed in a cryostat of 1.6 m diameter and 1.6 m height, and cooled down to about -200 C by two closed cycle coolers.

LUCI is built by a German consortium led by the Landessternwarte in Heidelberg. MPE contributes the MOS-unit handling the slit masks.

If you have questions concerning this site please contact:

**Reiner Hofmann**  
 Max-Planck-Institut für extraterrestrische Physik  
 Postfach 1312  
 D-85741 Garching  
 Germany